



## — technical data type **VEL**

**Housing:** - Injection moulded housing made out of ABS  
 - Standard white coloured.  
**- Optional:** Semi recessing bezel.

**Diffuser:** - Injection moulded diffuser, fixed to the housing with screws, made out of polycarbonate (PC).  
 - Pictograms optional. (self adhesive legend kits)

**- Optional:** Trapezium shape diffuser (h=150 mm) inclusive self-adhesive safety signs to provide double sided signage.

**Reflector:** - Hinged white plastic.

**2 Types:** Both 150lm output

- VEL/EM3: Maintained or Non-Maintained with 3H autonomy and battery 1x3.6V (1.5 Ah NiCd).

**- Optional:** LiFe PO<sub>4</sub> batteries

- VEL/230: LED mains only (bulkhead).



### Specifications:

- Complies with glow wiretest at 850°C.
- 150 lumen out of fitting for 3,0W with 16 high output white LEDs.
- Supply voltage 230V/50Hz.
- Color 4000 to 5000 K.
- CRI > 80.
- Lifetime > 50.000 h

**- Optional:** DALI digital self test in accordance with BSEN62034.



Optional: trapezium shape diffuser

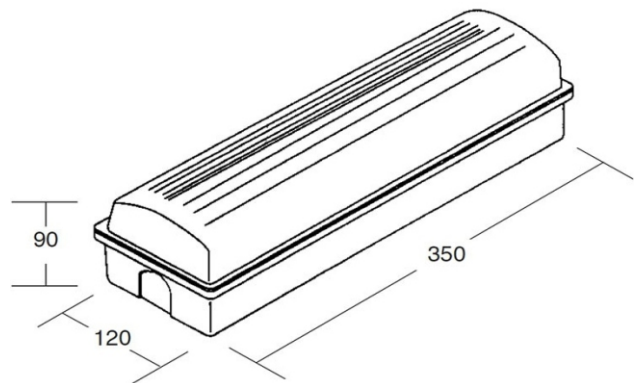

**Weight:** - VEL/EM3 = 1,1 kg  
 - VEL/230 = 0,9 kg



VLUX  
 Industrieweg Roosveld  
 3400 LANDEN BELGIUM

Tel. + 32 11 88 09 00

website [www.vlux.com](http://www.vlux.com)  
**ISO 9001 certified company.**

